

## AIR EXCHANGER

**vånEE Air Exchanger**  
**Part no. 1601510**

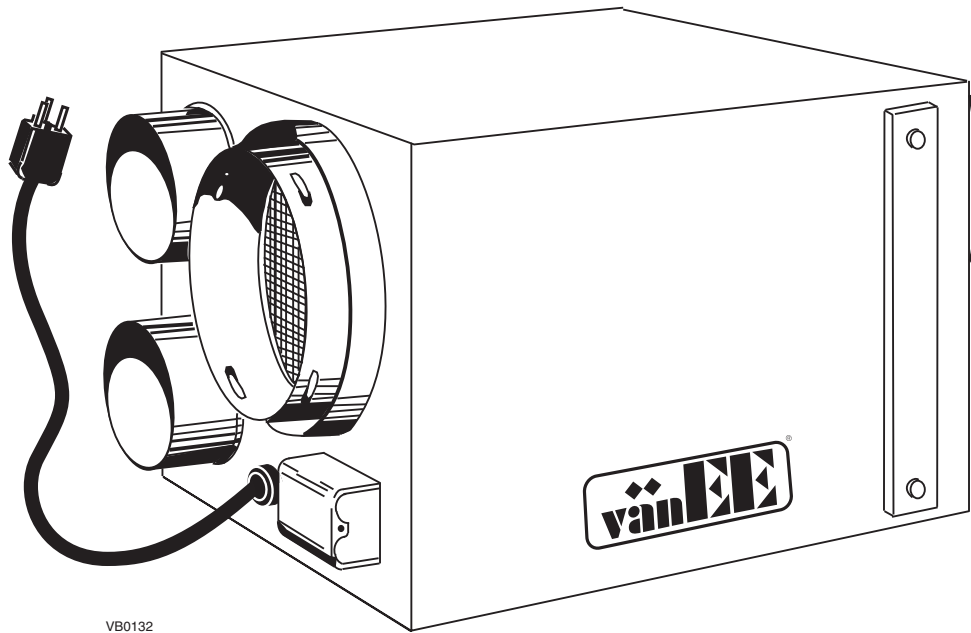

***A BASIC VENTILATION SYSTEM, ECONOMIC AND ROBUST, THAT CONTROLS EXCESS HUMIDITY. IDEAL FOR BUNGALOWS OR SMALL SURFACE AREAS.***

- Air exchange with outdoors. Exhausts stale air out and brings fresh air in.
- Controls the excess humidity level in the house.
- Mechanical air filtration by a washable filter.
- 6"Ø (15.54 cm Ø) ambient air intake and air outlet to facilitate installation in new houses.
- Plug-in module, simplifying the installation.
- Dehumidistat wall control (120 V).
- Complete two-year warranty on parts.

Available at:

## Dimensions

- Dimensions: 18¼" x 12¼" x 15"  
(46.4 cm x 31.1 cm x 38.1 cm).
- Weight: 40 lb. (18 kg)
- Electrical characteristics:
  - Voltage: 120 V
  - Power: 200 watts
  - Amperage: 3.0 amperes

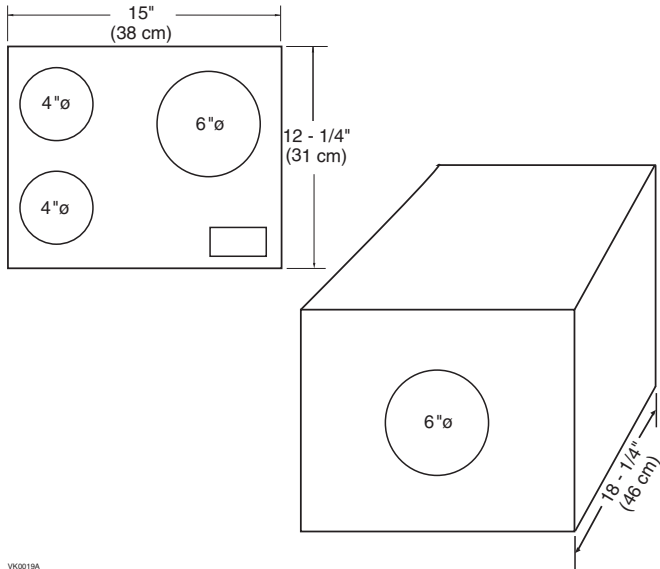

VK0019A

## Air flow while exchanging

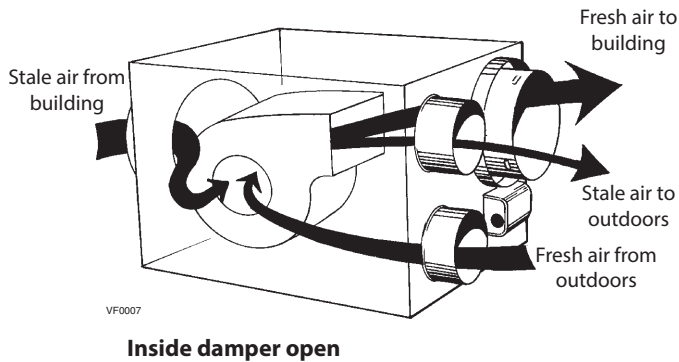

VF0007

## Installation

### BASEMENT INSTALLATION MODEL

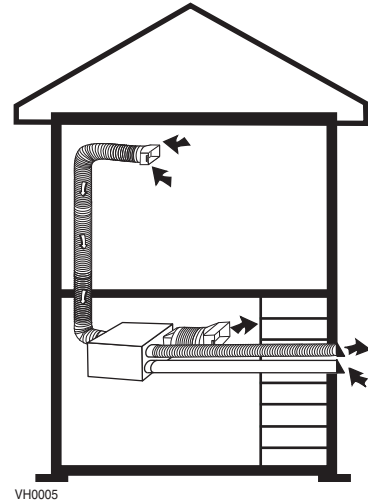

VH0005

## Ventilation rates

- Fresh air intake: 60 cfm (30 l/s)
- Stale air exhaust: 80 cfm (40 l/s)
- Circulation rate: 250 cfm (125 l/s)

## Warranty

vänEE air exchangers are covered by a full, two-year warranty against all parts or manufacturing defects which may affect the operation of the unit. The warranty applies where the damage is not the result of a poor installation, improper use, mistreatment or negligence, act of God, or any circumstance beyond the control of Venmar Ventilation ULC.

Project:	REMARKS
Location:	
Part Number: 1601510	
Quantity:	
Submitted by: _____ Date: _____	



Residential Product Group, 550 Lemire Blvd., Drummondville, Qc, Canada J2C 7W9 - Tel.: 1-800-67-3855 Fax: 1-800-567-1715

www.vanee.ca

90407 (14\_12)

